



$$P^p_{k|k-1} \equiv A_{k,k-1} P^a$$

## MiniSense2

Operational Principles and integrating with the future of ocean current measurements

Presented by:

Neil Manning, Chris Malzone



# What is this all about?

- Motion
- Experienced on “most” platforms including
  - Tripods
  - Moorings
  - Wire walkers (McLane Profilers)
  - AUV’s..... Both propelled & buoyancy driven (Gliders)
- The accelerations about the Center of Gravity (CoG) on these platforms biases velocity
- The problem is that cost-effective off-the-shelf solutions are “noisy” and the high resolution inertial (INS) based systems are really expensive (\$40k plus)
- Need a cost-effective INS based solution... but who & what?

# The Flow

- CDL Navigation
  - Capabilities
  - Products
- The Solution... Minisense2
- Integration with Nortek
- Applications
- Targeted Beta Integrations

- *In house software design*
- *Display and support for CDL product range*
- *Software design for specific client applications*

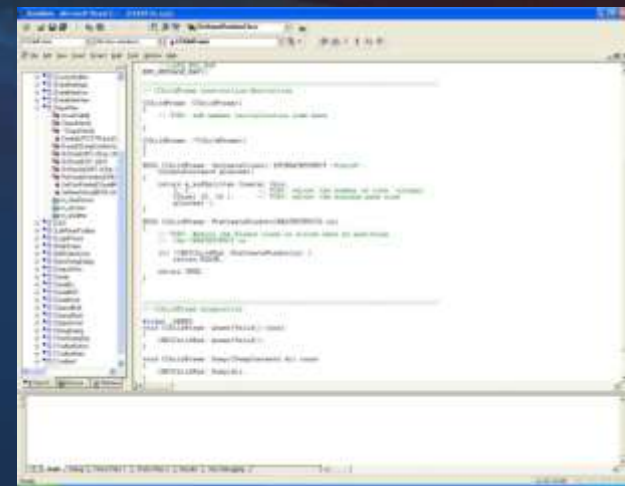



## MiniSense2

Low cost 6 DoF MEMS sensor –  
INS capable device

The Minisense2 is a 6 Degree's of Freedom Sensors that has been developed based on MEMS technology, by utilising an even higher accuracy MEMS sensor CDL have achieved significant improvements in performance.

The MiniSense2 can provide high accuracy Heave, Pitch & Roll Data as well as have 3 linear and 3 rotational rate gyro's offering RAW acceleration outputs. Each sensor contains a embedded computer which provides serial and network output data formats in addition to the Karman filter and localised flash on board memory .



6 Degree's of Freedom Sensor

Magnetic Aiding – *(Using rotation rate gyro's from the 6DoF sensor)*

AHRS Mode / Static Mode / Heave / GPS Aiding / DVL Aiding  
/ USBL Aiding

Compact / Low Cost

RS232 / RS422 / Ethernet (dual comms port's)

Surface to Ocean Depth Packaging



# MiniSense2 Magnetic Heading (Aided)

Two test runs were completed as follows:

- a) MiniSense2 after local field calibration with INS aiding disabled
- b) MiniSense2 after local field calibration with INS aiding enabled

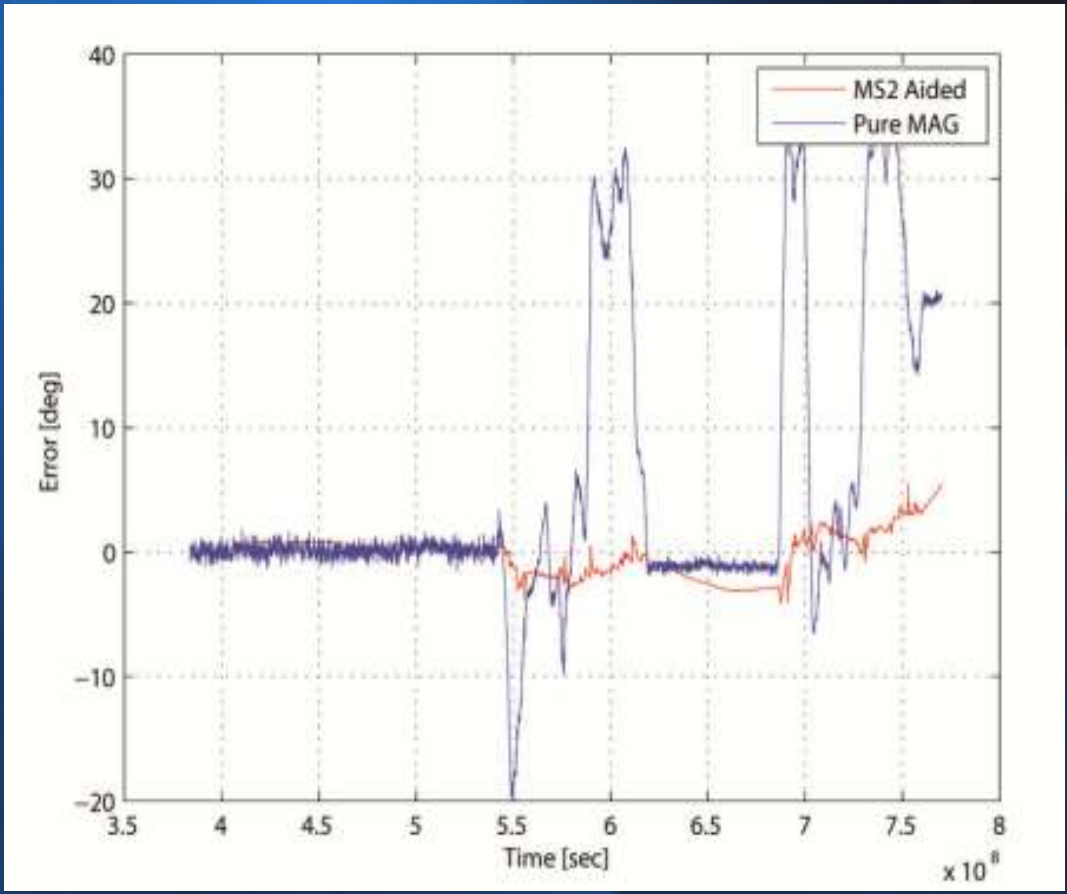

## Heading Change (Pitch Error)

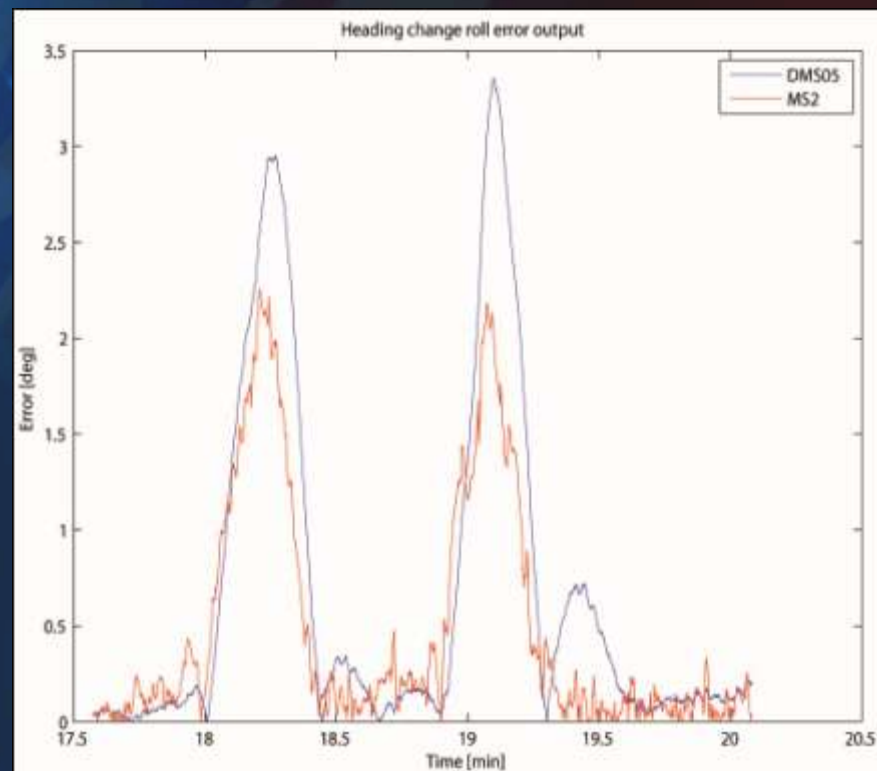
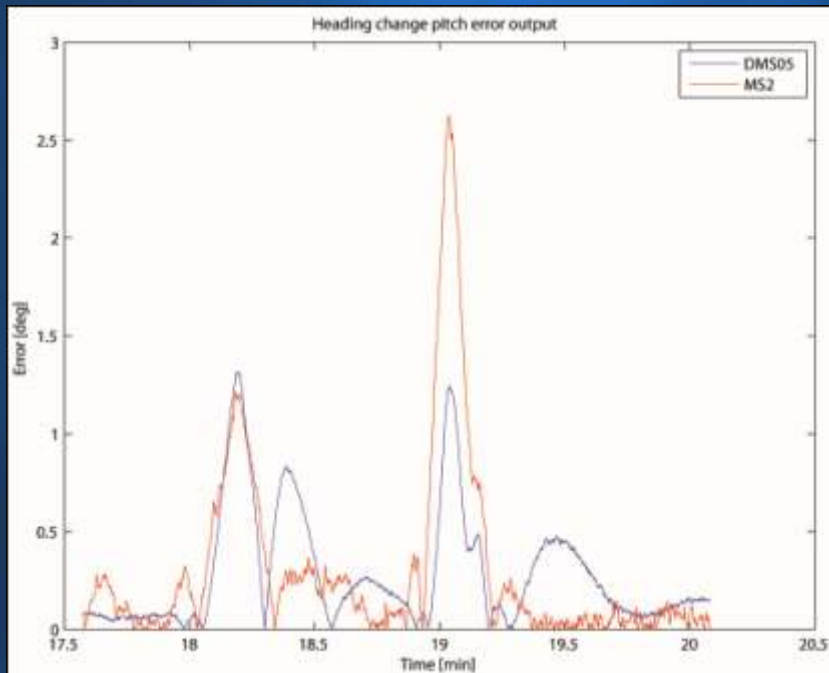

## Dynamic Accuracy

Heave	7cm or 7% (which ever is greater)
Pitch	0.15 Deg
Roll	0.15 Deg

## Resolution

Heave	1cm
Pitch	0.01 deg
Roll	0.01 deg

**Power** 10-36 VDC (5 VDC optional)



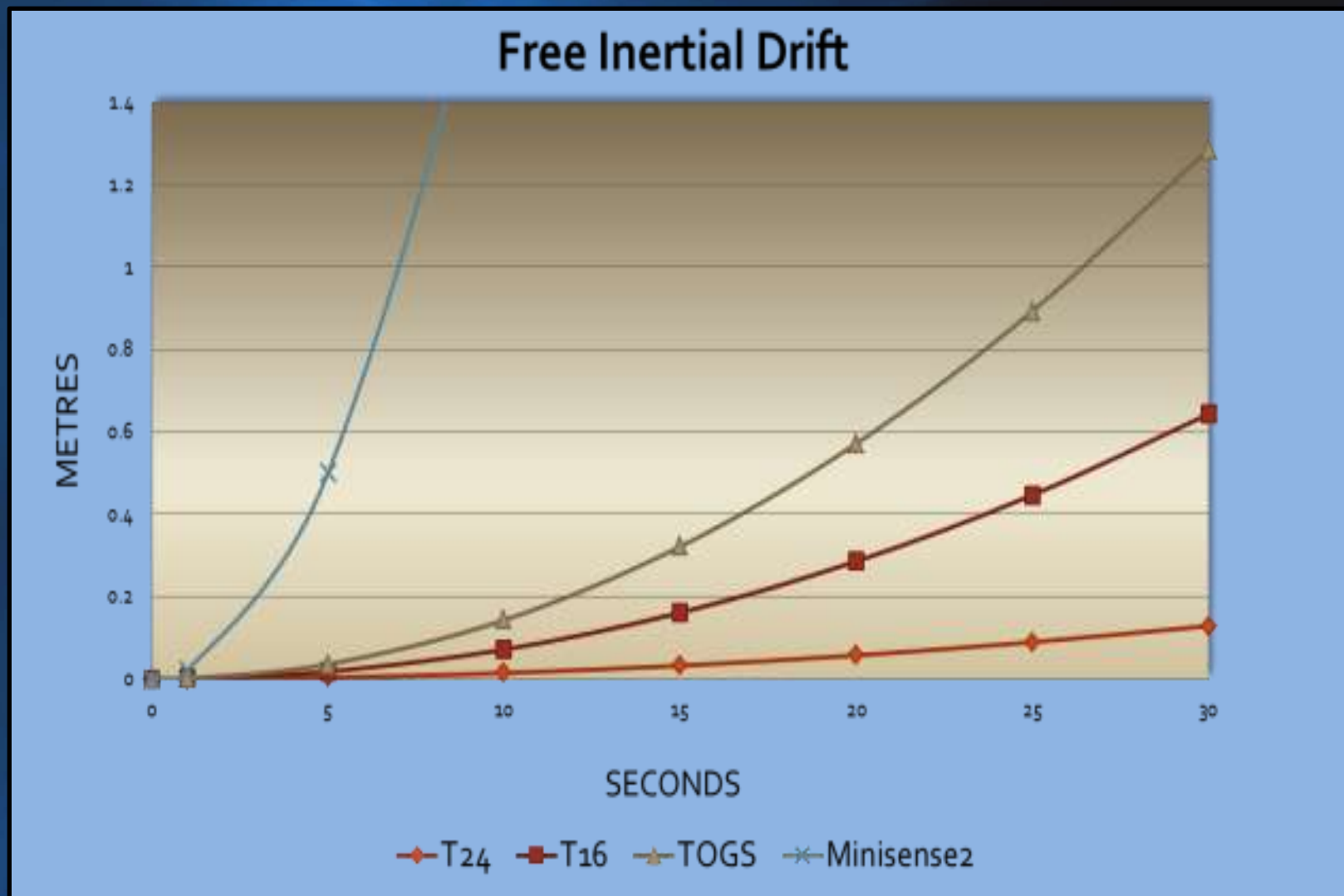

# Integration with Nortek

- Why?
- Addresses Needs in 2 main areas
- Offshore Fatigue Monitoring Applications
  - ✓ Correlate Vortex Induced Vibration with Current Velocities
    - Aquadopp Single-Point Current Meter → Risers, Spars, etc
    - Vector Velocimeter → Mooring lines
- Renewable Marine Hydrokinetic Applications
  - ✓ Correct Vector measurements taken at “hub height” for MHK turbines

# Monitoring Fatigue

- Waves: Stresses in the joints of steel jacketed offshore structures are continuously fluctuating under the influence of the continuously acting waves loads.
- Currents: Slender marine structures (eg risers, moorings , wind towers) are very sensitive to excitation from vortex shedding, which results in resonant vibrations transverse to the flow direction of ocean currents.
- For certain combinations of waves and currents the vortex shedding develops into a structural resonance phenomenon known as locking-on. These resonance vibrations have been destructive to some structures and have lead to collapse.

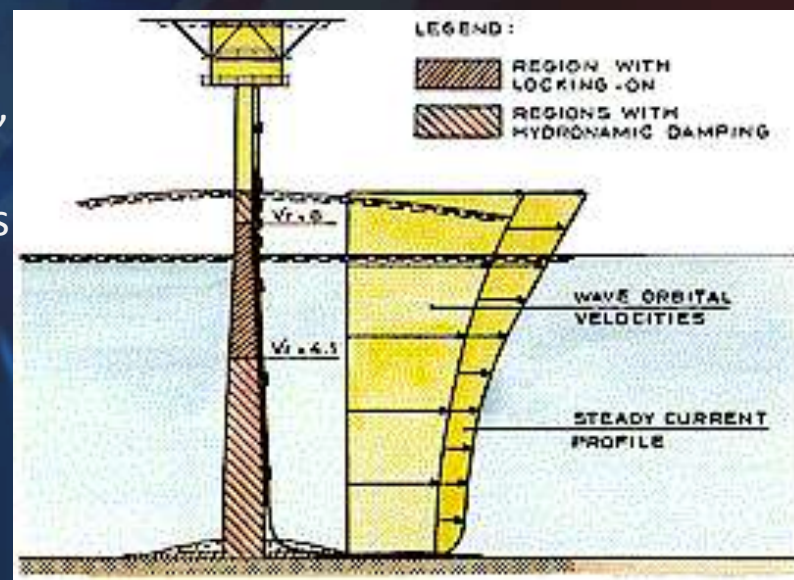

# Riser Monitoring

- NTL 2005-G05 dictates that all floating mobile offshore drilling units, and production facilities (with certain exceptions) operating or installed in water depths greater than 400m must continuously monitor and gather ocean current data in a real-time basis from near the ocean surface (~30m) to ~1000m using acoustic Doppler current profiles (ADCP) current monitoring or compatible equipment.
- According to BOEMR (MMS), this NTL has “Nothing to do with Oceanography but everything to do with monitoring fatigue”
- Problem is the Currents and Structural Measurements are “de-coupled”..... Measurements are made away & to the side of the Riser and do not reflect any changes in the “forcing” on the riser due to flow disturbances of the rig

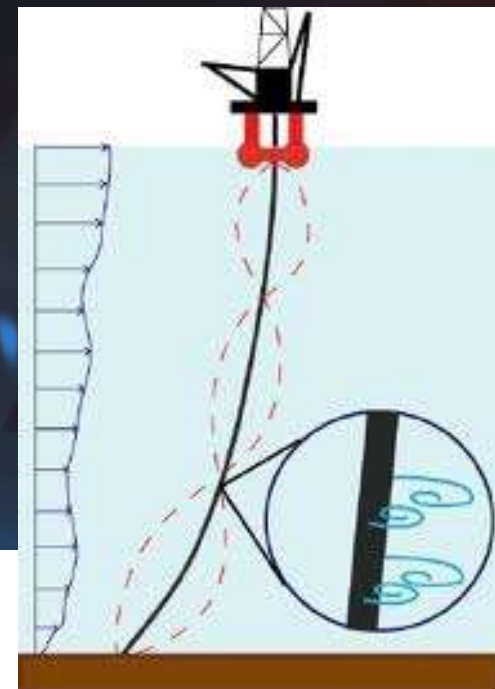

④ ( )

# Marine Hydrokinetic

- Several requests have come for solutions that will help in the analysis of turbulence at the “hub height” of MHK turbines
- Problem is that there isn't an instrument that can “remotely” measure the desired turbulent structures
- Must use an ADV mounted on a “vane” however the vane “vibrates” A LOT
- Need a solution to “correct” the data for vane vibrations

## Turbulence intensity $\langle u' / \bar{u} \rangle$

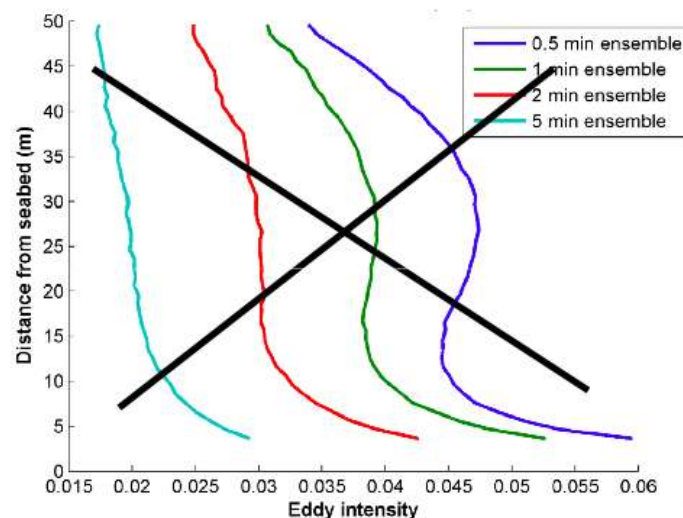

New deployment to get TKE spectra at hub height

From Jim Thomson 2010 Symposium Presentation “*Harnessing the Tides: Siting and monitoring a new technology*”

# Aquadopp Integration

- Temporal variability
  - Ocean Currents: Order of Minutes
  - Vortex Induced Vibration: 8 to 10 Hz
- To monitor this variability you need to look at:
  - The 3 components of velocity: u, v, w
  - Accelerations of the structural (eg riser) as vortex shedding induces vibration
- Aquadopp: will provide a direct measurement of the average currents at the “point of forcing”
- CDL Minisense2: will provide out to 50 Hz motions & is mounted inside the Aquadopp or Vector Pressure Housing
- Instruments are configured separately & both data sets are logged onto “separate” channels on the MS2 logger board

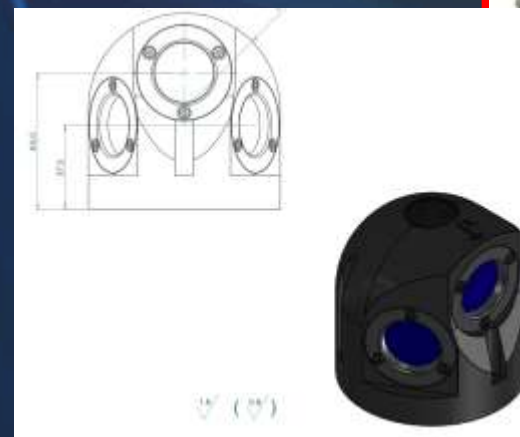

# Vector Integration

- For smaller scale structures and/or for MHK applications the MS2 can be integrated with the Vector
  - Anchor Lines
  - Mooring Lines
  - “Underwater Turbulence Vanes”
- This now introduces an old friend to a new partner... The Vector!
- Utilizes same modified endbell design
- Sampling between MS2 and Vector are fully synchronized utilizing the “Start on Sync” and “Sample on Sync” check boxes in the Vector software.
- All sampling is controlled by the MS2 out to 50 Hz



# Summary on how this works

- Fits onto a customized endbell for a pressure ratings for the Aquadopp & Vector
- Has a separate two channel datalogging card (up to 64 Gb)
- Data strings are logged separately
- Takes up the same amount of space as a single battery (100mm in height)
- Must configure Aquadopp & MS2 separately at this stage
- Vector must be configured in its own SW to “Start” & “Sample” on sync
  - MS will send out a TTL pulse to start the sampling
  - MS will send out 50 Hz pulses to control the sampling
  - All data is fully sync’d

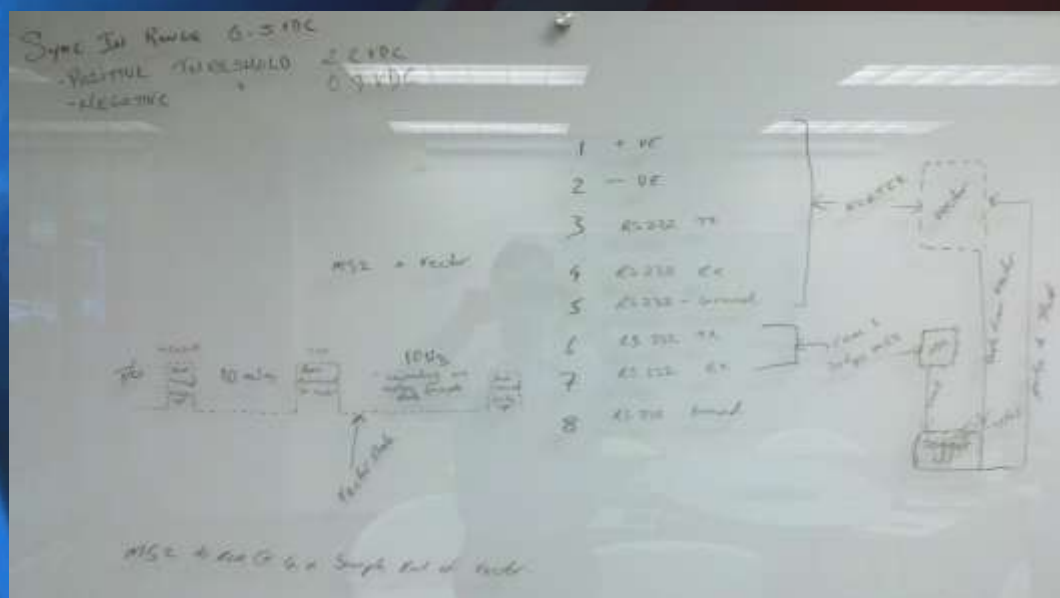

Pic from the CDL Nortek Meeting board last month

# Recap

- CDL Minisense2 represents a compact, cost effective INS solution for obtaining 6 degrees of freedom motions
- Coupled with a Data logger it represents an solution that can be autonomously deployed
- OR... Due to its small size, it can be installed the pressure housing of either a Nortek Aquadopp or Vector to:
  - Vortex Induced Vibration as a function of current velocity
  - Better data for estimating fatigue
  - A “first” truly integrated step in finding a way to correct velocities on moving and/or vibrating structures
- What we need:
  - Someone to provide a processing solution for correcting velocity data for motions