

# Doppler Ltd

Lee Gordon  
Kent Deines

Lithium Batteries  
Consulting  
Laser Doppler  
Audio Distribution



# AWAC Lithium Battery Packs



# Derating Factor vs. Temperature and Duration

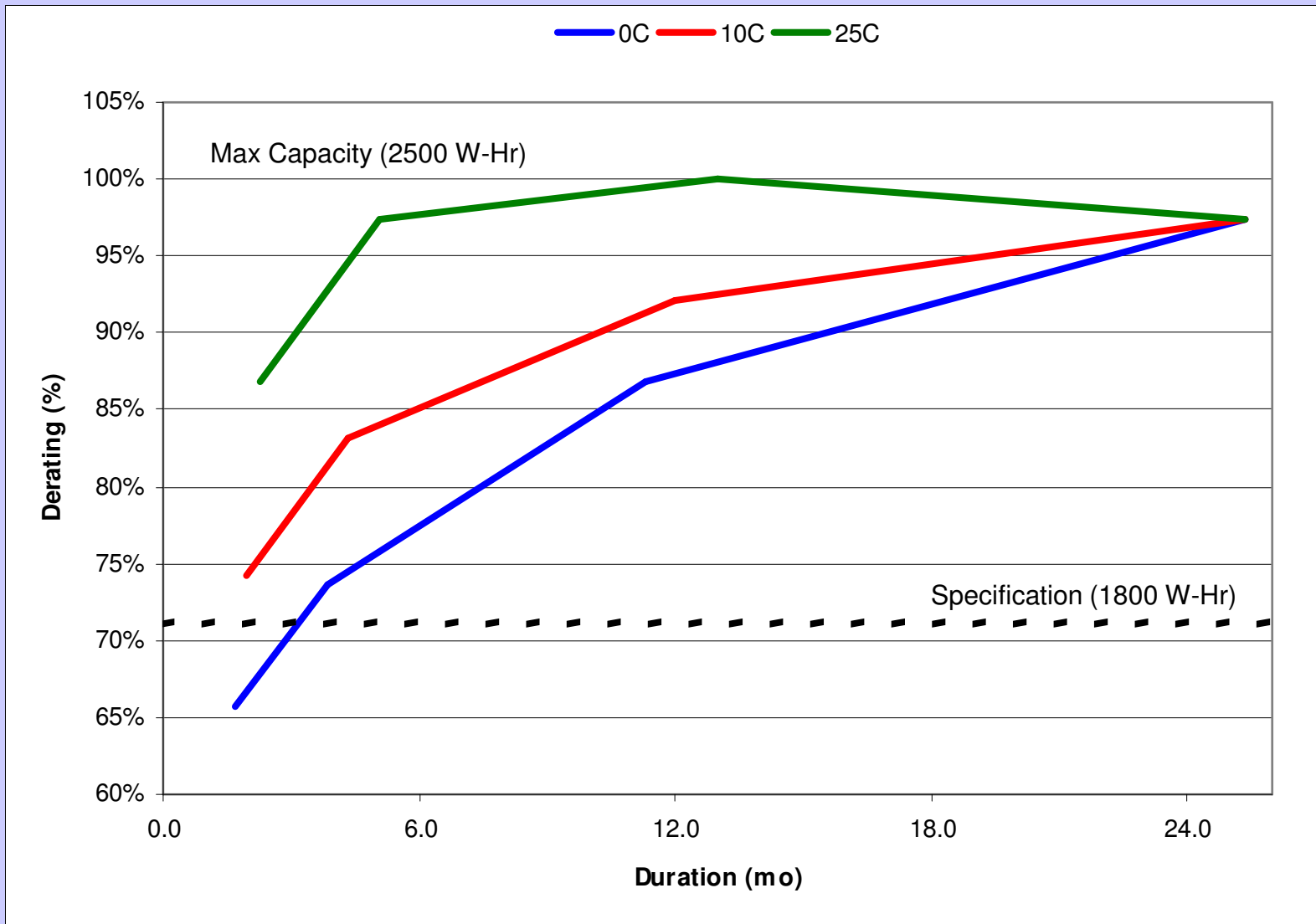

# Battery Pack Construction

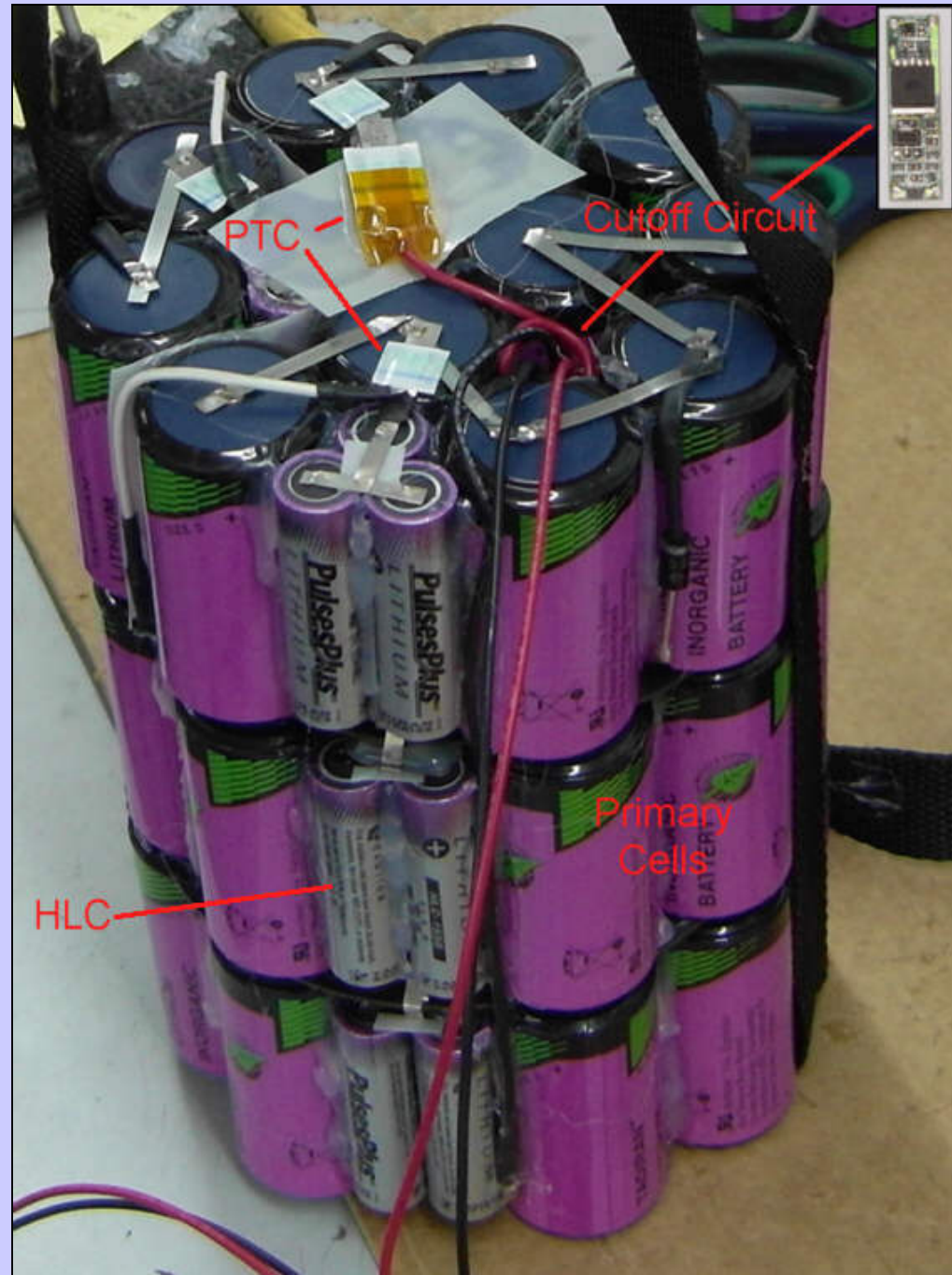

# Hermetic Seal

*Non-pressurized interior*

*No outgassing*

## Bobbin Design

*Low Current*  
*More Lithium*

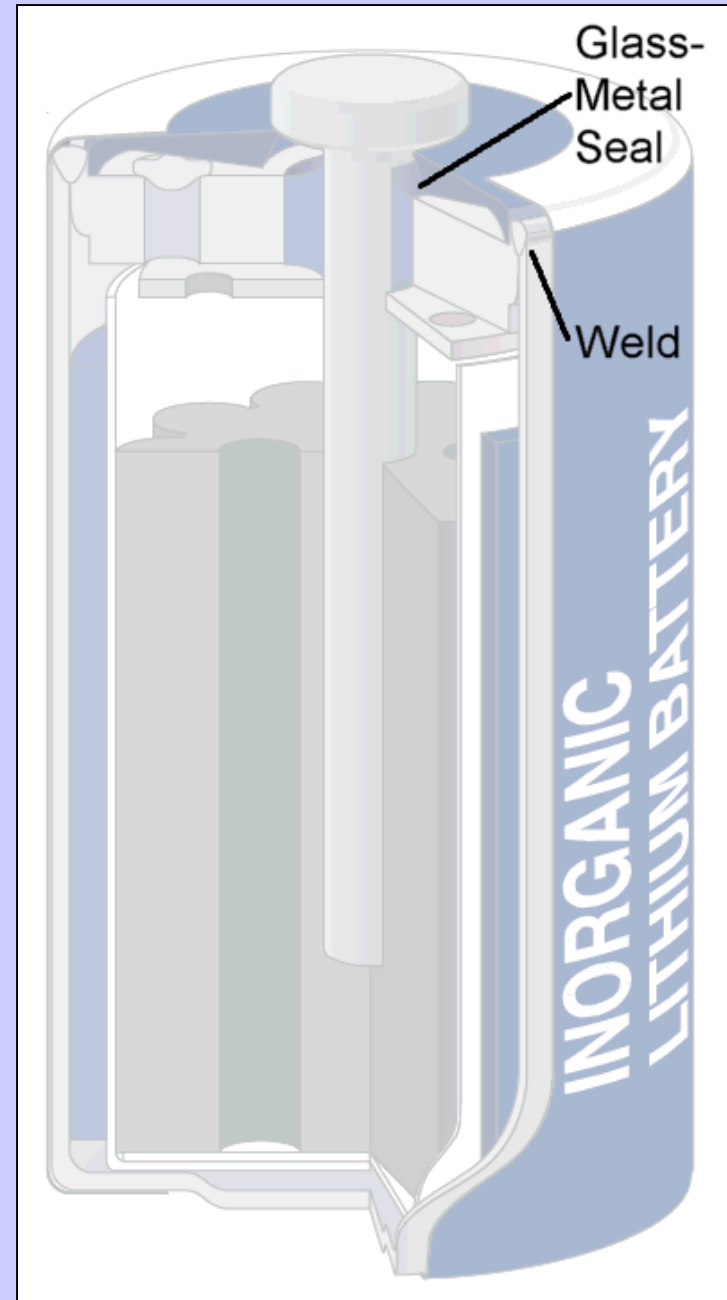

# Schematic

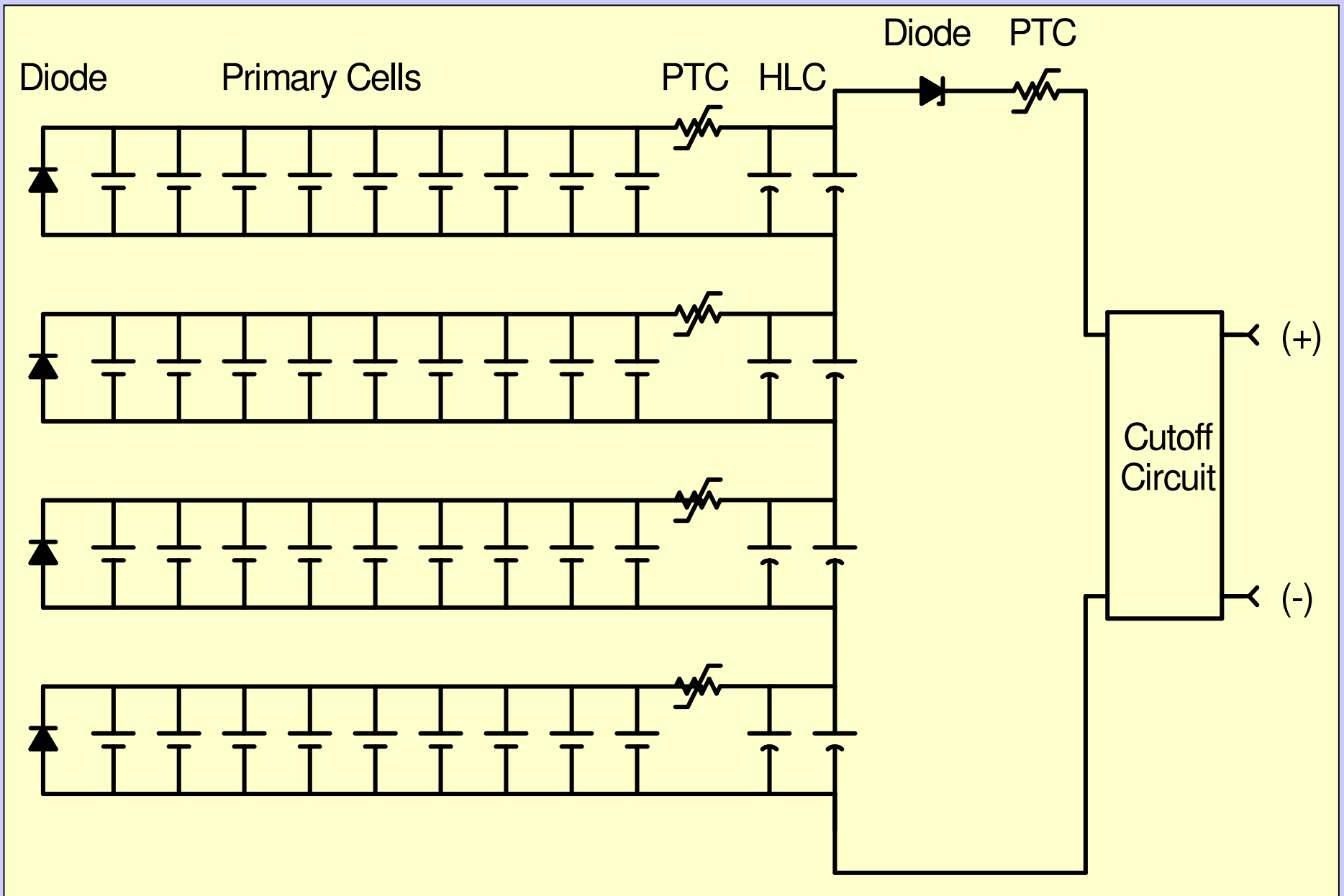

# Handling

- Storage: keep dry! best if kept cool (up to 75C is okay, but packs last longer at <35C)
- Transport: Class 9 UN 3090, Lithium metal batteries.
  - Must go by ground or cargo aircraft
  - Relatively easy by UPS or FedEx in US, Canada & Mexico
  - International more difficult
  - Do **NOT** bring on jet as carry-on luggage!
  - Malcolm Williams or Lill Lohrmann can advise
- Disposal: ToxCo Inc.  
3200E Frontera, Anaheim, California 92806  
Tel: (714) 879 2076, Fax: (714) 441 0857  
<http://www.toxco.com/>  
*(no heavy metals)*

# Nominal Depletion Curve

