



EVANS-HAMILTON, INC.

Integration of Nortek Vector Into a Real-time Met Station

Presented by Trap Puckette

Evans-Hamilton, Inc.- Charleston Office



Background:

Eastern Carolina University required real-time MetOcean data in the central part of Albermarle Sound, NC.

US Coast Guard gave permission for the station to be installed on navigation marker platform



Background:

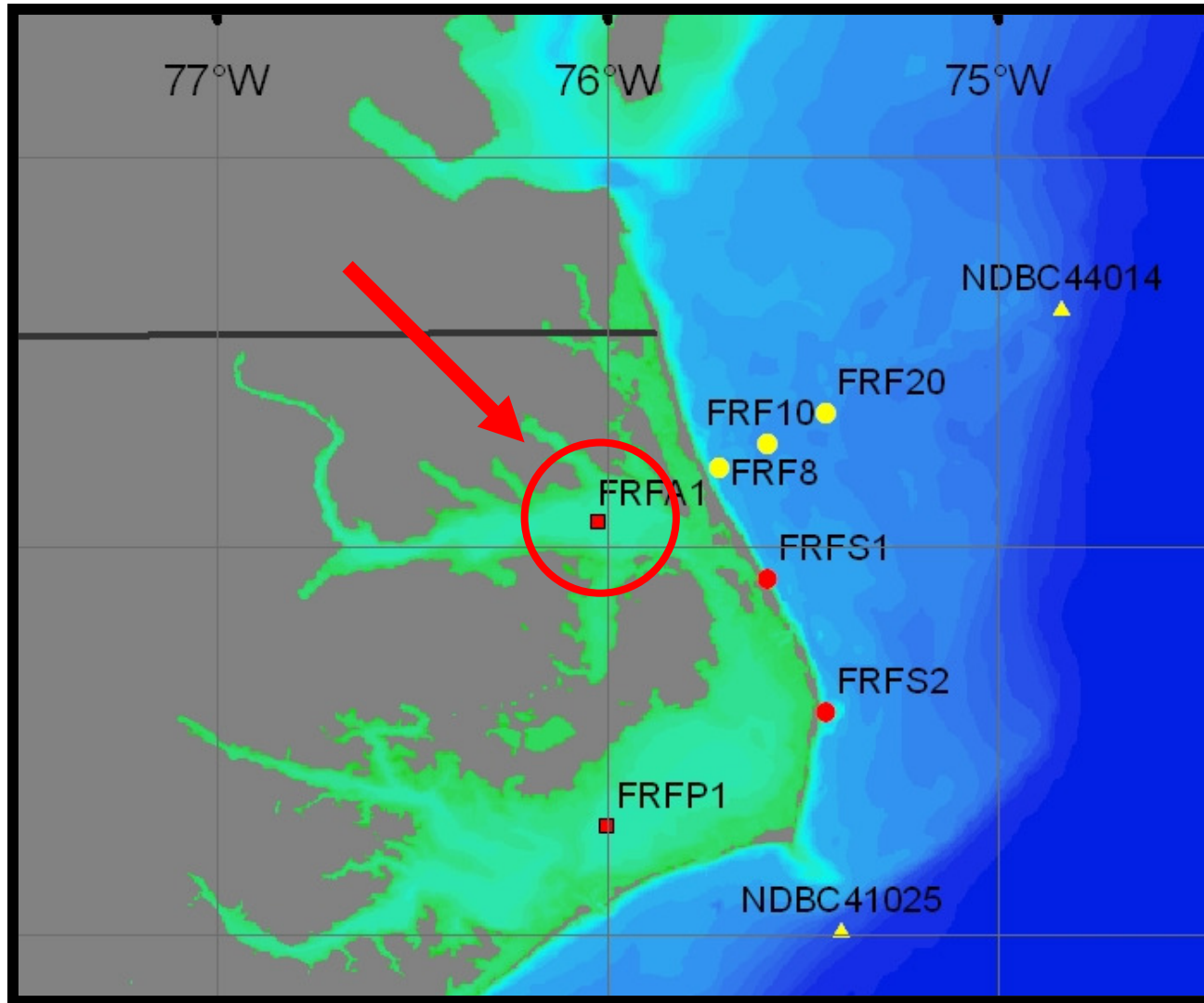

Background:

Requirements:

- Needed a small footprint due to limited space on tower
- Could not obstruct USCG light or solar panel
- Provide at least hourly data real-time
- No shore station
- Targeted ~ 2 month servicing

Background:

Parameters included:

- Wind
- Temperature
- Barometric pressure
- Humidity
- Rainfall
- Vector output (currents & waves)
- Water quality - Vector (turbidity & salinity)
- Water level
- Water quality – standalone (turbidity, salinity, DO & chlorophyll)

Approach:

Used off-the-shelf components to minimize cost and permit for flexibility in sensor selection

Datalogger –	Campbell Scientific CR1000
Met Station –	Standard components with an ultrasonic wind sensor
Water level –	Paros pressure sensor with serial output
Vector –	1.5 MHz with serial output
Water quality	Integrated into Vector through analog channels
WQM	Wetlabs WQM with serial output
Power	12 v AGM battery with solar panel and charge controller
Communications	Airlink cellular modem with data service

Approach:

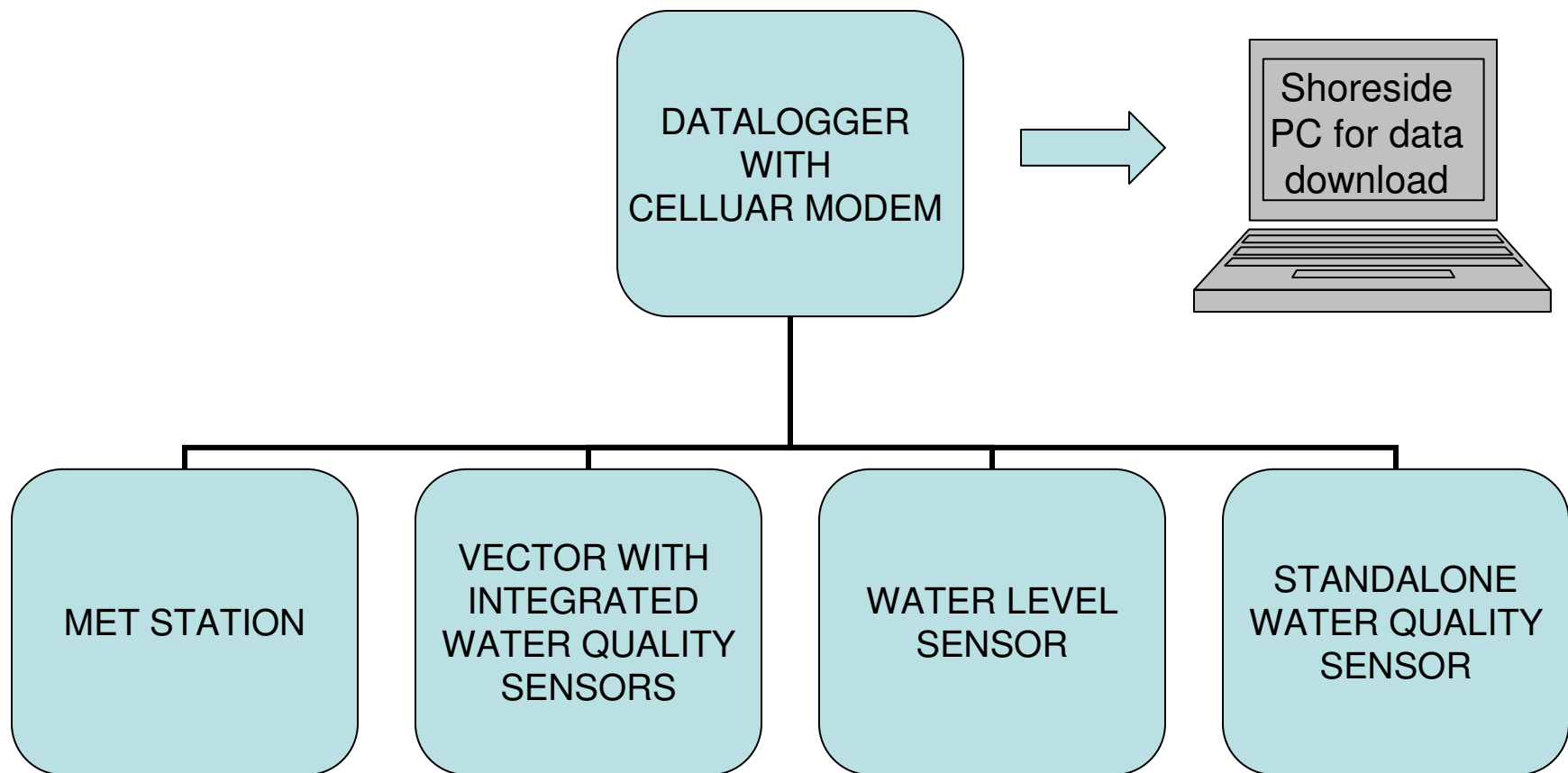

Instrumentation:

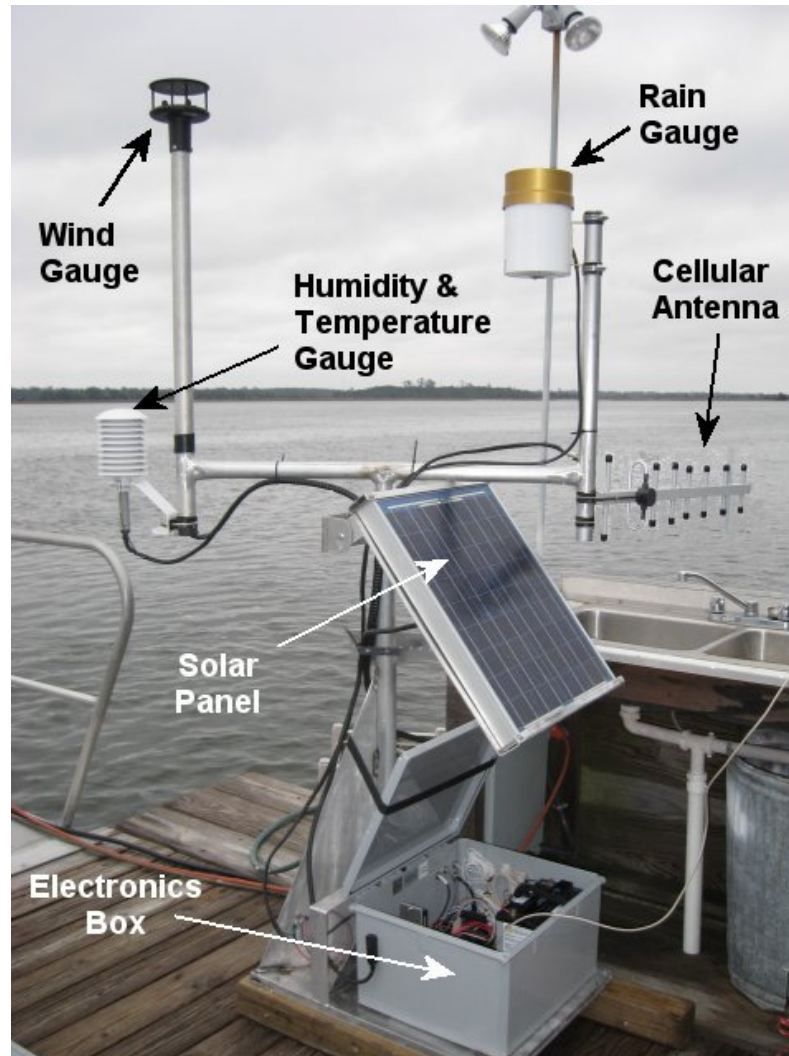

Instrumentation:

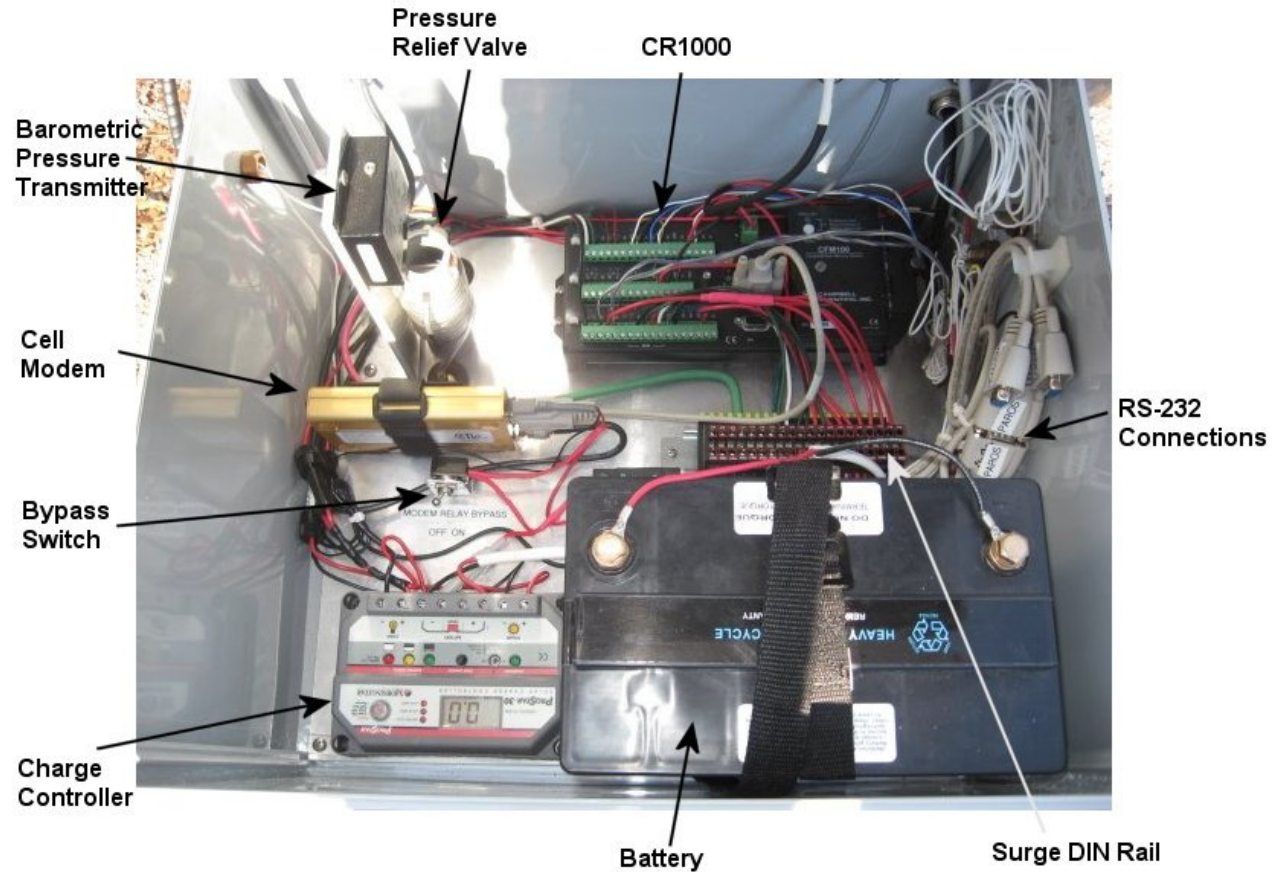

Instrumentation:

OCEANOGRAPHIC SENSORS

Vector and OBS/Salinity Sensor – deployed on a separate frame approximately 50 feet away from the pile. Connected to station via a double armor cable.

Water level sensor –
deployed on pile below the station

Wetlabs WQM –
deployed on pile below the station



Instrumentation:

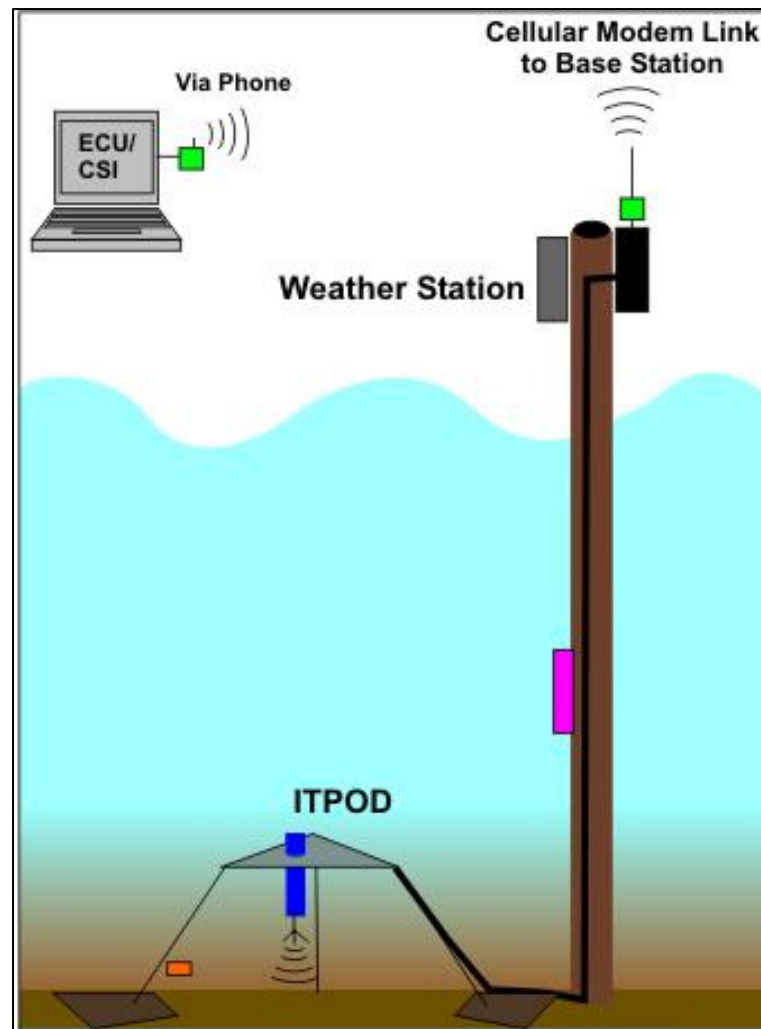

Sampling Protocol:

MET DATA

All values except rainfall:

Sampled at 30 minute intervals for 4 minutes and data stored in user defined data tables.

Average values reported along with wind standard deviation and wind gust

Rainfall reported every hour

VECTOR

Samples once an hour collecting data at 8 Hz for ~4.25 minutes resulting in 2048 samples (OBS and salinity sensors integrated into the vector sampled at the same frequency)

WQM: samples once per hour at 1 Hz for 120 seconds

Challenges:

Datalogger typically setup to store data into user defined tables.

Vector designed to operate in internal recording mode or for real-time mode connected to a computer.

Vector outputs binary only

- Complicates troubleshooting
- Parsing out relevant data for storage to data tables difficult

Vector files are large.

Challenges:

Datalogger typically controls data output from sensors

- cycling power
- polling sensor

Sampling control of Vector by external means requires vector be in standby mode which results in high power consumption

No delayed start.

Challenges:

Datalogger typically controls data output from sensors

- cycling power
- polling sensor

Sampling control of vector by external means requires vector be in standby mode which results in high power consumption

No delayed start.

SOLUTION

Vector programmed to sample autonomously and output data string

Vector sampling manually initiated at predefined time

Datalogger opens serial port and logs data file

Requires clocks stay synced

Each hour data recorded to a file named with date and time which is stored on the datalogger

File size ~70Kb

Data Transmission:

Cellular modem used to establish a data link between the datalogger and the cellular services server.

Shore based computer runs Campbell Scientific Software Loggernet

User defines data recovery schedule

Once per hour Loggernet connects to datalogger and downloads any new data since the last download. Any new Vector or WQM files that were created are downloaded as well.

Met station and WQM data are ASCII files. Vector is binary and requires conversion.

Data Conversion:

Vector files –

Since it is intended that the Vector be connected to a PC for real-time conversion, data packets sent from Vector have header information removed. Therefore, to convert files, binary header information has to be inserted.

Files converted to ASCII with Vector conversion software or Matlab script.

Converted data then can be analyzed for wave data using Quickwave or Matlab scripts.

EHI is in the process of automating data conversion.

Summary

- Small met/oceanographic system is providing a wide array of real-time measurements.
- Design allows for flexibility in sensor selection and ability to swap out sensors.
- System can be easily replicated.

Suggested Modifications

- Delayed start when setup for serial output.
- Ability to control what is included in output data string.
- Ability to send a command to wake vector up and initiate sampling.
- More detail in system documentation.